

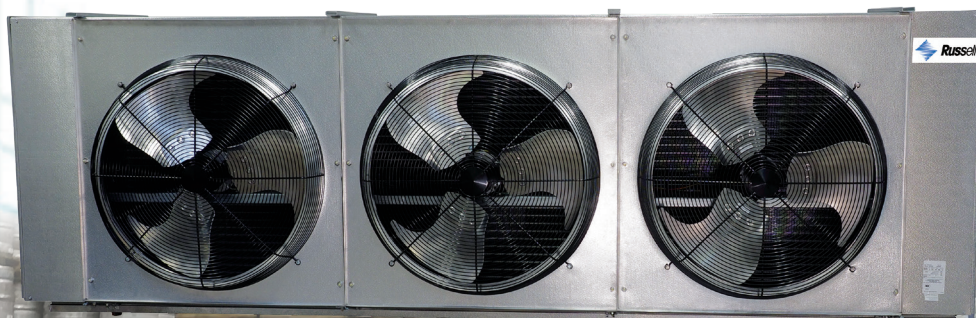


Publication No. RU-RHX-1021A  
Replaces RU-RHX-0221A

# HEAVY DUTY UNIT COOLER

Medium to Large Walk-Ins  
Cooler and Freezer Applications

Designed for Walk-in Coolers and Freezers in boxes less than 3,000 sq. ft.



Air Defrost  
31,200 to 253,100 BTUH

Electric Defrost  
33,100 to 227,400 BTUH

Hot Gas Defrost  
33,100 to 227,400 BTUH



Models were designed in anticipation of the July 2020 Department of Energy Annual Walk-in Energy Factor (AWEF) regulations for evaporators for Walk-in Coolers and Freezers in boxes less than 3,000 sq. ft. See pages 13-14 for AWEF compliance ratings.

# HEAVY DUTY UNIT COOLER

## Features

Russell's Heavy Duty Unit Coolers are the ideal evaporator solution for medium and large walk-in coolers and freezers. Designed with efficiency, performance and service in mind, the Heavy Duty Cooler line is optimized to cover Cold Storage applications in the most effective way. The Heavy Duty units were engineered to meet the Department of Energy's new AWEF performance regulations and feature energy-efficient rail-mount Dual Speed EC Motors. All units are circuited for multiple refrigerants and feature optimized circuit patterns to maximize performance. Heavy Duty Unit Coolers have several enhanced service features including rail-mount motors, new high efficiency fan and venturi designs, enhanced surface coil tubing, easily removable fan guards and modular fan panels, face mount defrost heaters, hinged drain pans and shipping pallets designed to facilitate easy installation.

### SIZES

There are a wide array of sizes to match your specific application requirements ranging from 31,200 to 253,100 BTUH at a 10°TD. Models are available with air flow spanning a range of 5,750 to 24,000 CFM.

### HOUSING

Each unit is constructed with a rust-free, heavy gauge, textured, aluminum housing which is light weight yet extremely durable. Models feature hinged drain pans to allow for convenient servicing and maintenance. Pre-drilled hanger holes are provided on all units for fast installation.

### COIL

Seamless copper tubes are staggered and mechanically expanded into heavy gauge corrugated aluminum fins to assure maximum heat transfer. Die formed fin collars are provided for accurate fin spacing. Heavy gauge hangers are fastened directly to the tube sheet of the coil to provide high structural strength. Electric Defrost and Hot Gas Defrost Models are available in both 6 FPI and 4 FPI.

### MOTORS

Standard models feature highly efficient Dual Speed Electronically Commutated (EC) motors, which are compliant with California Title 24 regulations<sup>1</sup>.

### FANS & FAN GUARDS

Powerful heavy-duty aluminum fans are individually balanced to provide vibration free operation. Standard heavy-gauge wire fan guards are UL/cUL-approved epoxy coated for corrosion resistance. Air throw for Heavy Duty Unit Coolers is 100 ft.

### REFRIGERANTS

Heavy Duty Unit Coolers are optimized for multiple refrigerants including R404A, R407A, R448A, R449A and R744 DX (CO<sub>2</sub>). Please specify system refrigerant requirements when ordering. A separate compartment is provided for all refrigerant connections which allows ample room for internal mounting of expansion valves.

### ELECTRICAL

Available in 208/230V/1<sup>2</sup>, 208-230V/3, 460V/1 or 460/3. A large compartment is supplied for all electrical components and is easily accessible by removing the end panel. All models are UL and cUL listed.

### AIR DEFROST

Air Defrost models (RH6A) are designed for use in coolers at +35°F and warmer.

### ELECTRIC DEFROST

Electric Defrost models (RH6E or RH4E) are designed for use in coolers and freezers between 35°F to -30°F. Electric Defrost 4 FPI models (RH4E) are designed for use in freezers between 32°F and -30°F. Defrost heaters are mounted on the air intake side of the unit for optimal performance and easy maintenance. A lower heater is installed inside the drain pan for fast, reliable drainage. Adjustable defrost termination, fan delay and heater safety controls are factory mounted for optimum performance of each control function.

### HOT GAS DEFROST

There are two types of Hot Gas Defrost models available: 3-pipe Hot Gas models (RH\*H or RH\*K) and 2-pipe Hot Gas Reverse Cycle units (RH\*G or RH\*L). Hot Gas Defrost 6 FPI models (RH6H, RH6K, RH6G, RH6L) are designed for use in coolers and freezers between 35°F and -30°F. Hot Gas Defrost 4 FPI models (RH4H, RH4K, RH4G, RH4L) are designed for use in freezers between 32°F and -30°F. All units include adjustable defrost termination and fan delay controls which are factory mounted for optimum performance of each control function. Refer to the current Russell Technical Bulletin for piping. Reverse Cycle units can also be used for Alternating Evaporator Systems.

### Optional Features

- EcoNet<sup>®</sup> Enabled Controller<sup>3</sup> (factory-installed)
- EcoNet<sup>®</sup> Command Center (loose)
- Reverse Connections
- Thermostat - Mechanical or Electric (mounted or loose)
- Thermostatic Expansion Valve (mounted or loose)
- Electronic Expansion Valve (mounted or loose)
- Liquid Line Solenoid Valve (mounted or loose)
- Insulated Drain Pan
- Painted Cabinet (White or Black)
- Stainless Steel Cabinet
- Coated Coil (Bronz-Glow, or Electrofin<sup>®</sup>)
- Heat Exchanger (loose)

### Notes

- \* AWEF (Annual Walk-in Energy Factor)
- 1. Single Compressor system without variable capacity.
- 2. Some limitations apply. For specific electrical offering, consult electrical data tables in this brochure.
- 3. EcoNet Control Package includes: EEV; suction pressure transducer; suction, entering air coil temp. thermistors; thru-the-door disconnect switch; local on-board two-row backlit LCD display and push-button adjustments. (Controller replaces TXV, liquid line solenoid valve, room thermostat, defrost termination and fan delay, and time clock.)



# HEAVY DUTY UNIT COOLER

## Highlighted Features and Options



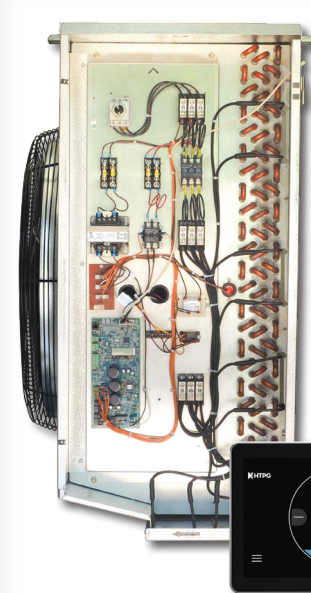
### FANS AND HOUSING


- 30" heavy duty aluminum fans are balanced for vibration-free operation
- High efficiency deep draw venturi provide optimal air flow
- Hinged panels that can easily be removed
- NSF approved



### COILS AND DEFROST HEATERS


- Available in 4 or 6 fins per inch (FPI)
- Electric defrost heaters are mounted on the air intake coil face to provide optimal performance and easy service access
- The drain pan heater is affixed to the drain pan and is easily accessed for service or cleaning





### ECONET ENABLED UNIT COOLERS (Optional)

- Developed in conjunction with Rheem Manufacturing specifically for walk-in coolers and freezers — it builds on the reliability and efficiency of Rheem's EcoNet technology
- Saves energy in refrigeration systems through precise superheat and space temperature control, fan cycling, and controlling how often the system goes into defrost based on compressor runtime
- Eliminates unnecessary defrosts
  - Maximizes energy efficiency with less compressor runtime
  - Reduces fan speed to 50% during off cycle for energy savings
- Can be used with a condensing unit in single and multiple evaporator installations as a group
- Optional **EcoNet Command Center** with intuitive graphical interface controls up to 32 devices (including the Command Center) through one display, provides continuous communication between system components, and the remote mount display allows for EcoNet Enabled Unit Coolers to be programmed, monitored and troubleshot outside of the space being cooled



## ELECTRICAL AND PIPING

- End panels slide out for easy service from the front or sides of the unit
- Ample room in electrical and piping compartments for easy access



# HEAVY DUTY UNIT COOLER

## MODEL NUMBER NOMENCLATURE

### CONFIGURABLE BASE MODEL

R	H	6	E	109	D	D	A
Brand	Style	Fins Per Inch (FPI)	Defrost Type	BTUH in Thousands	Unit Voltage	Motor Type	Vintage
R = Russell	H = Heavy Duty Y = Reverse Connections	4 6	A = Air E = Electric H = Hot Gas 3-Pipe - Electric Drain Pan G = Hot Gas Reverse - Electric Drain Pan K = Hot Gas 3-Pipe - Hot Gas Drain Pan L = Hot Gas Reverse - Hot Gas Drain Pan		D = 208-230/1/60 E = 208-230/3/60 F = 460/1/60 G = 460/3/60	D = Dual Speed EC	

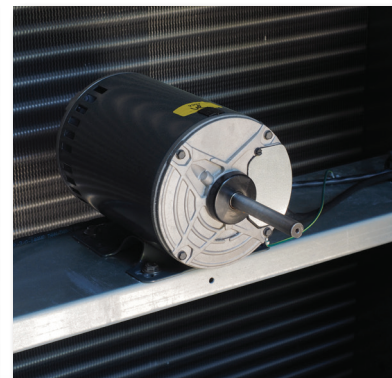
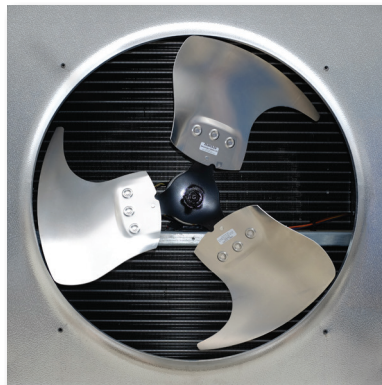
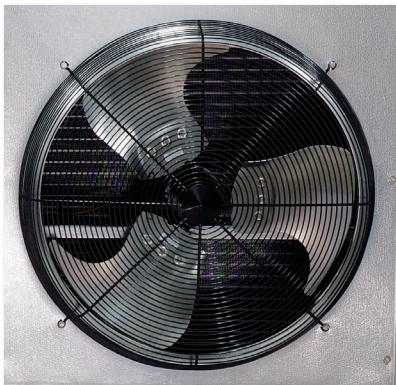
## EVAPORATOR APPLICATION RATINGS

Multiple conditions combine to determine the application capacity of an evaporator. Walk-in space temperature, relative humidity, saturated suction temperature difference, and outdoor ambient temperature. All of the factors are considered when calculating an evaporator application rating. These ratings are higher than the net capacity value used for DOE ratings (AWEF).

The AWEF of an evaporator is calculated using the dry coil capacity and the daily evaporator power consumption. Power consumption included fan and defrost power. Evaporator net capacity reported to the DOE database is dry coil capacity less the full power fan watts. DOE test conditions are at 10°F evaporator/SST temperature difference and less than 50% relative humidity and 96°F liquid temperature. These conditions create a uniform test method, but should not be used for equipment selection. The equipment selected would be oversized for the application.

Russell's published application ratings are a guideline for proper equipment selection. They account for true operating conditions experienced by equipment.

## Fan guards easily removable for quick access to fan blades and rail-mounted motors



# HEAVY DUTY UNIT COOLER

## Application Rating and Electrical Data - Air Defrost Models - 6 FPI

Model Number	BTUH Capacity @ 25°F S.T. & 10°F TD		CFM	No. of Fans	Total Fan Motor AMPS	
	R404A / R744 DX (CO <sub>2</sub> )	R407A/ R448A/ R449A <sup>^</sup>			Dual Speed EC <sup>†</sup> Motors	
					Motor Voltage	
					208-230V/1	460V/1
RH6A031*DA	31,200	36,600	5,920	1	6.3	3.1
RH6A043*DA	43,600	51,100	5,870			
RH6A052*DA	52,100	61,900	5,750			
RH6A063*DA	63,200	73,500	11,850	2	12.6	6.2
RH6A087*DA	87,900	103,500	11,730			
RH6A105*DA	105,200	124,900	11,500			
RH6A132*DA	132,500	155,800	17,600	3	18.9	9.3
RH6A156*DA	156,300	185,700	17,250			
RH6A175*DA	175,400	206,900	23,460	4	25.2	12.4
RH6A209*DA	209,500	253,100	23,000			

Model Number	208-230V/1				460V/1			
	MCA		MOPD		MCA		MOPD	
	Base Model	EcoNet Enabled <sup>1</sup>	Base Model	EcoNet Enabled <sup>1</sup>	Base Model	EcoNet Enabled <sup>1</sup>	Base Model	EcoNet Enabled <sup>1</sup>
RH6A031*DA	15.0	15.0	20	20	15.0	15.0	20	20
RH6A043*DA								
RH6A052*DA								
RH6A063*DA	15.0	16.2	20	20	15.0	15.0	20	20
RH6A087*DA								
RH6A105*DA								
RH6A132*DA	20.5	22.5	25	25	15.0	15.0	20	20
RH6A156*DA								
RH6A175*DA	26.8	28.8	30	30	15.0	15.0	20	20
RH6A209*DA								

\* Each asterisk represents a variable character based on voltage ordered. See page 4 for nomenclature.

<sup>^</sup> R407A, R448A and R449A are rated at dew point temperature. Use R407A capacity ratings for R407C and R407F.

<sup>†</sup> Dual Speed EC motors are compliant with California Title 24 regulations.

1. EcoNet Enabled Units are not powered by Condensing Unit so Defrost Heaters are incorporated into shown MCA/MOPD.

Models were designed in anticipation of the July 2020 Department of Energy Annual Walk-in Energy Factor (AWEF) regulations for evaporators for Walk-in Coolers and Freezers in boxes less than 3,000 sq. ft. See pages 13-14 for AWEF compliance ratings.

# HEAVY DUTY UNIT COOLER

## Application Rating and Electrical Data - Electric Defrost Models

Model Number	BTUH Capacity @ -20°F S.T. & 10°F TD <sup>1</sup>		CFM	No. of Fans	Total Fan Motor AMPS	
	R404A / R744 DX (CO <sub>2</sub> )	R407A/ R448A/ R449A <sup>^</sup>			Dual Speed EC Motors <sup>†</sup>	
					Motor Voltage	
					208-230V/1	460V/1

### 6 FPI

RH6E033*DA	33,100	38,700	5,920	1	6.3	3.1
RH6E044*DA	44,500	50,900	5,870			
RH6E053*DA	53,800	62,100	5,750			
RH6E066*DA	66,400	76,600	11,850	2	12.6	6.2
RH6E089*DA	89,400	102,300	11,730			
RH6E109*DA	109,200	125,700	11,500			
RH6E134*DA	134,500	153,800	17,600	3	18.9	9.3
RH6E163*DA	163,500	188,800	17,250			
RH6E199*DA	199,100	227,400	23,000			

### 4 FPI

RH4E035*DA	35,800	41,100	5,870	1	6.3	3.1
RH4E044*DA	44,000	50,800	5,750			
RH4E071*DA	71,400	83,000	11,730	2	12.6	6.2
RH4E087*DA	87,400	100,900	11,500			
RH4E107*DA	107,700	122,900	17,600	3	18.9	9.3
RH4E131*DA	131,900	152,300	17,250			
RH4E167*DA	167,000	190,200	23,000	4	25.2	12.4

Model Number	208-230V/3				Heater Amps			Heater Watts
	MCA		MOPD		208-230V/3			
	Base Model	EcoNet Enabled <sup>2</sup>	Base Model	EcoNet Enabled <sup>2</sup>	No. of Circuits	Amps Each Circuit	Total Heater Amps	

### 6 FPI

RH6E033EDA	15.0	16.4	20	20	1	14.4	14.4	6,000
RH6E044EDA								
RH6E053EDA								
RH6E066EDA	15.0	30.9	20	35	1	28.9	28.9	12,000
RH6E089EDA								
RH6E109EDA								
RH6E134EDA	20.5	45.3	25	50	1	43.3	43.3	18,000
RH6E163EDA								
RH6E199EDA	26.8	59.7	30	60	2	28.9	57.7	24,000

### 4 FPI

RH4E035EDA	15.0	16.4	20	20	1	14.4	14.4	6,000
RH4E044EDA								
RH4E071EDA	15.0	30.9	20	35	1	28.9	28.9	12,000
RH4E087EDA								
RH4E107EDA	20.5	45.3	25	50	1	43.3	43.3	18,000
RH4E131EDA								
RH4E167EDA	26.8	59.7	30	60	2	28.9	57.7	24,000

See notes on page 7.



# HEAVY DUTY UNIT COOLER

## Application Rating and Electrical Data - Electric Defrost Models continued

Model Number	460V/3				Heater Amps			Heater Watts
	MCA		MOPD		460V/3			
	Base Model	EcoNet Enabled <sup>2</sup>	Base Model	EcoNet Enabled <sup>2</sup>	No. of Circuits	Amps Each Circuit	Total Heater Amps	

### 6 FPI

RH6E033GDA RH6E044GDA RH6E053GDA	15.0	15.0	20	20	1	7.5	7.5	6,000
RH6E066GDA RH6E089GDA RH6E109GDA	15.0	16.1	20	20	1	15.1	15.1	12,000
RH6E134GDA RH6E163GDA	15.0	23.6	20	25	1	22.6	22.6	18,000
RH6E199GDA	15.0	31.1	20	35	1	30.1	30.1	24,000

### 4 FPI

RH4E035GDA RH4E044GDA	15.0	15.0	20	20	1	7.5	7.5	6,000
RH4E071GDA RH4E087GDA	15.0	16.1	20	20	1	15.1	15.1	12,000
RH4E107GDA RH4E131GDA	15.0	23.6	20	25	1	22.6	22.6	18,000
RH4E167GDA	15.0	31.1	20	35	1	30.1	30.1	24,000

Notes:

1.

Capacity Correction for Electric and Hot Gas Defrost Evaporators						
S.S.T. (Dew)	20°F	0°F	-10°F	-20°F	-30°F	-40°F
Multiply Capacity by:	1.15	1.075	1.0375	1	0.9625	0.925

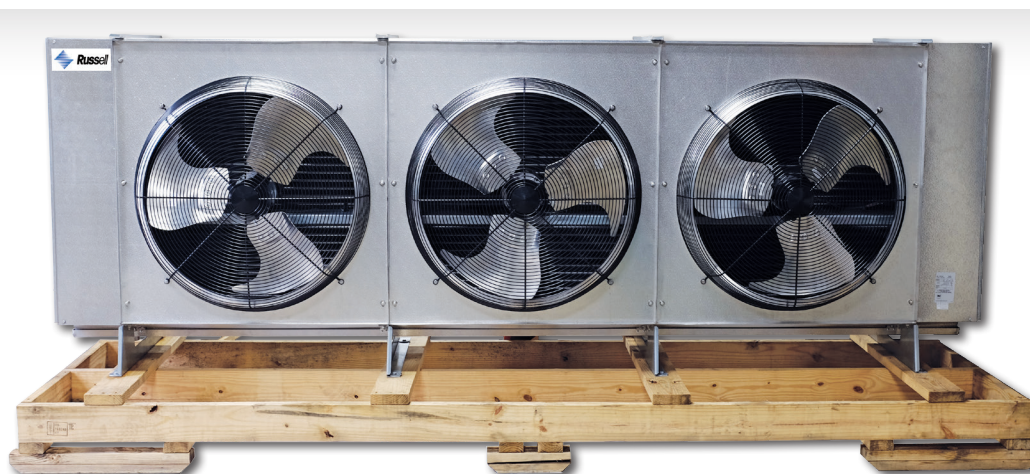
2. EcoNet Enabled Units are not powered by Condensing Unit so Defrost Heaters are incorporated into shown MCA/MOPD.

\* Each asterisk represents a variable character based on voltage ordered. See page 4 for nomenclature.

^ R407A, R448A and R449A are rated at dew point temperature. Use R407A capacity ratings for R407C and R407F.

† Dual Speed EC motors are compliant with California Title 24 regulations.

Models were designed in anticipation of the July 2020 Department of Energy Annual Walk-in Energy Factor (AWEF) regulations for evaporators for Walk-in Coolers and Freezers in boxes less than 3,000 sq. ft. See pages 13-14 for AWEF compliance ratings.



**Supports are bolted to pallet and unit cooler  
for product safety and quicker installation**

# HEAVY DUTY UNIT COOLER

## Application Rating and Electrical Data - Hot Gas 3-Pipe Defrost Models

Hot Gas 3-Pipe Model Number (RH*H, RH*K)	BTUH Capacity @ -20°F S.T. & 10°F TD <sup>1</sup>		CFM	No. of Fans	Total Fan Motor AMPS		MCA	
	R404A	R407A/ R448A/ R449A <sup>^</sup>			Dual Speed EC Motors <sup>†</sup>			
					Motor Voltage			
					208-230V/1	460V/1	208-230V/1	460V/1

### 6 FPI

RH6*033*DA	33,100	38,700	5,920	1	6.3	3.1	15.0	15.0
RH6*044*DA	44,500	50,900	5,870					
RH6*053*DA	53,800	62,100	5,750					
RH6*066*DA	66,400	76,600	11,850	2	12.6	6.2	15.0	15.0
RH6*089*DA	89,400	102,300	11,730					
RH6*109*DA	109,200	125,700	11,500					
RH6*134*DA	134,500	153,800	17,600	3	18.9	9.3	20.5	15.0
RH6*163*DA	163,500	188,800	17,250					
RH6*199*DA	199,100	227,400	23,000	4	25.2	12.4	26.8	15.0

### 4 FPI

RH4*035*DA	35,800	41,100	5,870	1	6.3	3.1	15.0	15.0
RH4*044*DA	44,000	50,800	5,750					
RH4*071*DA	71,400	83,000	11,730	2	12.6	6.2	15.0	15.0
RH4*087*DA	87,400	100,900	11,500					
RH4*107*DA	107,700	122,900	17,600	3	18.9	9.3	20.5	15.0
RH4*131*DA	131,900	152,300	17,250					
RH4*167*DA	167,000	190,200	23,000	4	25.2	12.4	26.8	15.0

Hot Gas 3-Pipe Model Number (RH*H, RH*K)	MOPD		Electric Drain Pan Heater Amps		Heater Watts
	208-230V/1	460V/1	208-230V/1	460V/1	

### 6 FPI

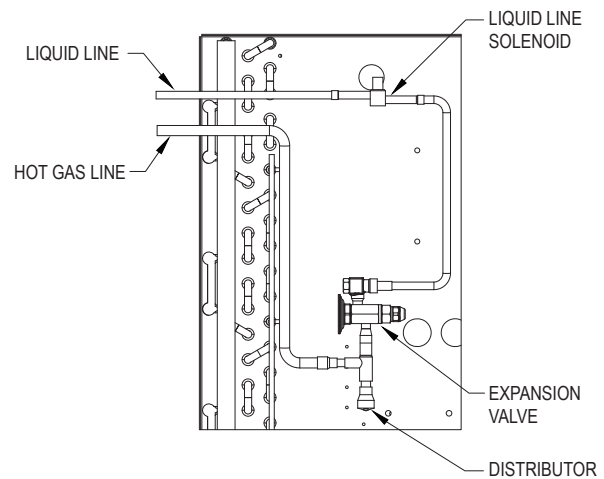
RH6*033*DA	20	20	8.3	4.3	2,000
RH6*044*DA					
RH6*053*DA					
RH6*066*DA	20	20	16.7	8.7	4,000
RH6*089*DA					
RH6*109*DA	25	20	25.0	13.0	6,000
RH6*134*DA					
RH6*163*DA	30	20	33.3	17.4	8,000
RH6*199*DA					

### 4 FPI

RH4*035*DA	20	20	8.3	4.3	2,000
RH4*044*DA					
RH4*071*DA	20	20	16.7	8.7	4,000
RH4*087*DA					
RH4*107*DA	25	20	25.0	13.0	6,000
RH4*131*DA					
RH4*167*DA	30	20	33.3	17.4	8,000

### Hot Gas 3-Pipe Model

The system uses 3 pipes — 1 for liquid line, 1 for suction line and 1 for hot gas. The hot gas is taken from the discharge line, between the compressor and the condenser, through a hot-gas solenoid valve to the distributor tee then through the coil.



\* Each asterisk represents a variable character based on voltage and defrost ordered. See page 4 for nomenclature.

1. See capacity correction table and additional notes on page 7.



# HEAVY DUTY UNIT COOLER

## Application Rating and Electrical Data - Hot Gas Reverse Cycle Defrost Models

Hot Gas Reverse Cycle Model Number (RH*G, RH*L)	BTUH Capacity @ -20°F S.T. & 10°F TD <sup>1</sup>		CFM	No. of Fans	Total Fan Motor AMPS		MCA	
	R404A	R407A/ R448A/ R449A <sup>^</sup>			Dual Speed EC Motors <sup>†</sup>			
					Motor Voltage			
					208-230V/1	460V/1	208-230V/1	460V/1

### 6 FPI

RH6*033*DA	33,100	38,700	5,920	1	6.3	3.1	15.0	15.0
RH6*044*DA	44,500	50,900	5,870					
RH6*053*DA	53,800	62,100	5,750					
RH6*066*DA	66,400	76,600	11,850	2	12.6	6.2	15.0	15.0
RH6*089*DA	89,400	102,300	11,730					
RH6*109*DA	109,200	125,700	11,500					
RH6*134*DA	134,500	153,800	17,600	3	18.9	9.3	20.5	15.0
RH6*163*DA	163,500	188,800	17,250					
RH6*199*DA	199,100	227,400	23,000					

### 4 FPI

RH4*035*DA	35,800	41,100	5,870	1	6.3	3.1	15.0	15.0
RH4*044*DA	44,000	50,800	5,750					
RH4*071*DA	71,400	83,000	11,730	2	12.6	6.2	15.0	15.0
RH4*087*DA	87,400	100,900	11,500					
RH4*107*DA	107,700	122,900	17,600	3	18.9	9.3	20.5	15.0
RH4*131*DA	131,900	152,300	17,250					
RH4*167*DA	167,000	190,200	23,000	4	25.2	12.4	26.8	15.0

Hot Gas Reverse Cycle Model Number (RH*G, RH*L)	MOPD		Electric Drain Pan Heater Amps		Heater Watts
	208-230V/1	460V/1	208-230V/1	460V/1	

### 6 FPI

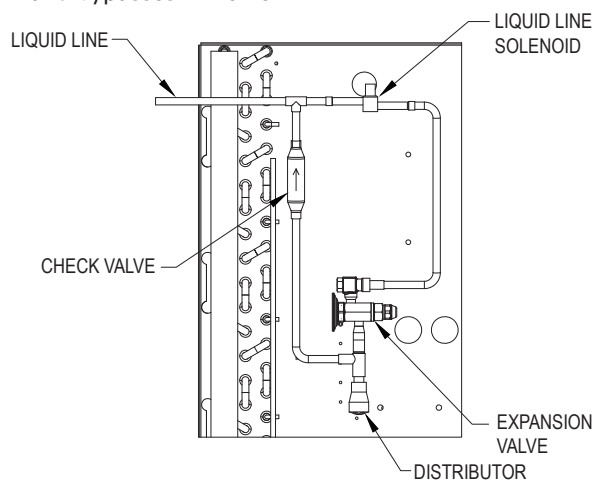
RH6*033*DA	20	20	8.3	4.3	2,000
RH6*044*DA					
RH6*053*DA					
RH6*066*DA	20	20	16.7	8.7	4,000
RH6*089*DA					
RH6*109*DA					
RH6*134*DA	25	20	25.0	13.0	6,000
RH6*163*DA					
RH6*199*DA	30	20	33.3	17.4	8,000

### 4 FPI

RH4*035*DA	20	20	8.3	4.3	2,000
RH4*044*DA					
RH4*071*DA	20	20	16.7	8.7	4,000
RH4*087*DA					
RH4*107*DA	25	20	25.0	13.0	6,000
RH4*131*DA					
RH4*167*DA	30	20	33.3	17.4	8,000

### Hot Gas Reverse Cycle 2-Pipe Model

A changeover valve is located in the discharge suction line of the compressor, so that when defrost is required, the valve changes over from the normal refrigeration flow so that the discharged gas flows into the suction connection and bypasses TX valve.



\* Each asterisk represents a variable character based on voltage and defrost ordered. See page 4 for nomenclature.

1. See capacity correction table and additional notes on page 7.

# HEAVY DUTY UNIT COOLER

## Distributor Nozzle and Expansion Valves - Air Defrost Models

Model Number	Part Numbers						No. of Circuits
	Nozzle @ Liq. Temp.		TXV <sup>^</sup> @ Liq. Temp.		EEV @ Liq. Temp.		
	50°F	100°F	50°F	100°F	50°F	100°F	

### R404A

6 FPI	RH6A031*DA	G-1-1/2	G-4	SBFSE-B-C	SBFSE-C-C	SER-C	SER-C	6
	RH6A043*DA	G-1-1/2	G-5	SBFSE-C-C	OSE-6-C	SER-C	SER-C	6
	RH6A052*DA	E-2	E-6	SBFSE-C-C	OSE-6-C	SER-C	SER-D	12
	RH6A063*DA	E-2-1/2	E-10	OSE-6-C	OSE-6-C	SER-C	SER-D	9
	RH6A087*DA	C-3	C-12	OSE-6-C	OSE-9-C	SER-D	SER-D	18
	RH6A105*DA	C-4	C-15	OSE-9-C	OSE-9-C	SER-D	SERI-F	18
	RH6A132*DA	C-5	C-20	OSE-9-C	OSE-12-C	SER-D	SERI-F	18
	RH6A156*DA	C-6	C-25	OSE-9-C	OSE-12-C	SERI-F	SERI-G	24
	RH6A175*DA	A-8	A-25	OSE-12-C	OSE-21-C	SERI-F	SERI-G	27
RH6A209*DA	A-10	A-30	OSE-12-C	OSE-21-C	SERI-F	SERI-G	36	

### R407A/ R448A/ R449A†

6 FPI	RH6A031*DA	G-1-1/2	G-4	SBFDE-B-C	SBFDE-C-C	SER-B	SER-C	6
	RH6A043*DA	G-1-1/2	G-5	SBFDE-C-C	SBFDE-C-C	SER-C	SER-C	6
	RH6A052*DA	E-2	E-6	SBFDE-C-C	EBSDE-7-C	SER-C	SER-C	12
	RH6A063*DA	E-2-1/2	E-8	SBFDE-C-C	EBSDE-7-C	SER-C	SER-D	9
	RH6A087*DA	C-4	C-12	EBSDE-7-C	EBSDE-10-C	SER-D	SER-D	18
	RH6A105*DA	C-4	C-15	EBSDE-7-C	ODE-12-C	SER-D	SERI-F	18
	RH6A132*DA	C-5	C-17	EBSDE-10-C	ODE-12-C	SER-D	SERI-F	18
	RH6A156*DA	C-6	C-20	EBSDE-12-C	ODE-17-C	SERI-F	SERI-F	24
	RH6A175*DA	A-8	A-25	EBSDE-12-C	ODE-17-C	SERI-F	SERI-G	27
RH6A209*DA	A-10	A-30	EBSDE-17-C	ODE-28-C	SERI-F	SERI-G	36	

Note: The distributor lines are 1/4" tube & 31" long.

\* Each asterisk represents a variable character based on voltage ordered. See page 4 for nomenclature.

<sup>^</sup> TXV selections are based on +25°F suction temp., 8°F to 12°F evaporator TD. Contact factory for operating conditions outside of this range.

<sup>†</sup> SBFDE, ODE, and EBSDE expansion valves are compatible with R407A, R448A and R449A/B. For other valves, follow manufacturers selection guidelines.

Base models (no factory-mounted components) include nozzles sized for 100°F liquid shipped loose.



Russell's Heavy Duty Unit Cooler can be used in combination with Next-Gen II Condensing Units to provide complete refrigeration solutions for medium and large walk-ins less than 3,000 sq. ft.

# HEAVY DUTY UNIT COOLER

## Distributor Nozzle and Expansion Valves - Electric Defrost Models

Model Number	Part Numbers						No. of Circuits
	Nozzle @ Liq. Temp.		TXV <sup>^</sup> @ Liq. Temp.		EEV @ Liq. Temp.		
	50°F	100°F	50°F	100°F	50°F	100°F	

### R404A

6 FPI	RH6E033*DA	E-3	E-8	SBFSE-C-Z	EBSSE-6-Z	SER-C	SER-C	9
	RH6E044*DA	E-4	E-10	OSE-6-Z	EBSSE-7-1/2-Z	SER-C	SER-C	9
	RH6E053*DA	E-5	E-12	OSE-6-Z	EBSSE-10-Z	SER-C	SER-D	12
	RH6E066*DA	C-6	C-17	OSE-6-Z	EBSSE-10-Z	SER-C	SER-D	18
	RH6E089*DA	C-10	C-20	OSE-9-Z	EBSSE-13-Z	SER-D	SER-D	18
	RH6E109*DA	C-12	C-25	OSE-12-Z	OSE-21-Z	SER-D	SERI-F	24
	RH6E134*DA	A-15	A-35	OSE-12-Z	OSE-30-Z	SER-D	SERI-F	27
	RH6E163*DA	A-17	A-40	OSE-21-Z	OSE-30-Z	SERI-F	SERI-G	36
RH6E199*DA	A-20	A-50	OSE-35-Z	OSE-45-Z	SERI-F	SERI-G	36	
4 FPI	RH4E035*DA	E-3	E-8	SBFSE-C-Z	OSE-6-Z	SER-C	SER-C	9
	RH4E044*DA	E-4	E-12	OSE-6-Z	OSE-6-Z	SER-C	SER-C	12
	RH4E071*DA	C-8	C-17	OSE-6-Z	OSE-12-Z	SER-C	SER-D	18
	RH4E087*DA	C-10	C-20	OSE-9-Z	OSE-12-Z	SER-D	SER-D	24
	RH4E107*DA	A-12	A-30	OSE-12-Z	OSE-21-Z	SER-D	SERI-F	27
	RH4E131*DA	A-15	A-35	OSE-12-Z	OSE-30-Z	SER-D	SERI-F	36
	RH4E167*DA	A-20	A-40	OSE-21-Z	OSE-30-Z	SERI-F	SERI-G	36

### R407A/ R448A/ R449A†

6 FPI	RH6E033*DA	E-2-1/2	E-6	SBFDE-C-Z	ODE-7-Z	SER-B	SER-C	9
	RH6E044*DA	E-4	E-8	EBSDE-7-Z	ODE-12-Z	SER-C	SER-C	9
	RH6E053*DA	E-5	E-12	EBSDE-7-Z	ODE-12-Z	SER-C	SER-C	12
	RH6E066*DA	C-6	C-15	EBSDE-10-Z	ODE-12-Z	SER-C	SER-D	18
	RH6E089*DA	C-8	C-17	ODE-12-Z	ODE-17-Z	SER-D	SER-D	18
	RH6E109*DA	C-12	C-25	ODE-17-Z	ODE-28-Z	SER-D	SER-D	24
	RH6E134*DA	A-15	A-30	ODE-17-Z	ODE-28-Z	SER-D	SERI-F	27
	RH6E163*DA	A-17	A-35	ODE-28-Z	ODE-40-Z	SERI-F	SERI-G	36
RH6E199*DA	A-20	A-40	ODE-28-Z	ODE-45-Z	SERI-F	SERI-G	36	
4 FPI	RH4E035*DA	E-3	E-6	SBFDE-C-Z	ODE-7-Z	SER-C	SER-C	9
	RH4E044*DA	E-4	E-8	SBFDE-C-Z	ODE-7-Z	SER-C	SER-C	12
	RH4E071*DA	C-6	C-15	ODE-12-Z	ODE-12-Z	SER-C	SER-D	18
	RH4E087*DA	C-8	C-17	ODE-12-Z	ODE-17-Z	SER-D	SER-D	24
	RH4E107*DA	A-12	A-20	ODE-17-Z	ODE-28-Z	SER-D	SER-D	27
	RH4E131*DA	A-15	A-30	ODE-17-Z	ODE-28-Z	SER-D	SERI-F	36
RH4E167*DA	A-17	A-35	ODE-28-Z	ODE-40-Z	SERI-F	SERI-G	36	

Note: The distributor lines are 1/4" tube & 31" long.

\* Each asterisk represents a variable character based on voltage ordered. See page 4 for nomenclature.

<sup>^</sup> TXV selections for Electric Defrost Models are based on -20°F suction temp., 8°F to 12°F evaporator TD. Contact factory for operating conditions outside of this range. Do not use pressure limiting TXVs when the condensing unit includes a CPR valve.

† SBFDE, ODE, and EBSDE expansion valves are compatible with R407A, R448A and R449A/B. For other valves, follow manufacturers selection guidelines.

Base models (no factory-mounted components) include nozzles sized for 100°F liquid shipped loose.



# HEAVY DUTY UNIT COOLER

## Distributor Nozzle and Expansion Valves - Hot Gas Defrost Models

Model Number RH*H/RH*G/ RH*K/ RH*L	Part Numbers						No. of Circuits
	Nozzle @ Liq. Temp.		TXV <sup>^</sup> @ Liq. Temp.		EEV @ Liq. Temp.		
	50°F	100°F	50°F	100°F	50°F	100°F	

### R404A

6 FPI	RH6*033*DA	E-3	E-8	SBFSE-C-Z	EBSSE-6-Z	SER-C	SER-C	9
	RH6*044*DA	E-4	E-10	OSE-6-Z	EBSSE-7-1/2-Z	SER-C	SER-C	9
	RH6*053*DA	E-5	E-12	OSE-6-Z	EBSSE-10-Z	SER-C	SER-D	12
	RH6*066*DA	C-6	C-17	OSE-6-Z	EBSSE-10-Z	SER-C	SER-D	18
	RH6*089*DA	C-10	C-20	OSE-9-Z	EBSSE-13-Z	SER-D	SER-D	18
	RH6*109*DA	C-12	C-25	OSE-12-Z	OSE-21-Z	SER-D	SERI-F	24
	RH6*134*DA	A-15	A-35	OSE-12-Z	OSE-30-Z	SER-D	SERI-F	27
4 FPI	RH4*035*DA	E-3	E-8	SBFSE-C-Z	OSE-6-Z	SER-C	SER-C	9
	RH4*044*DA	E-4	E-12	OSE-6-Z	OSE-6-Z	SER-C	SER-C	12
	RH4*071*DA	C-8	C-17	OSE-6-Z	OSE-12-Z	SER-C	SER-D	18
	RH4*087*DA	C-10	C-20	OSE-9-Z	OSE-12-Z	SER-D	SER-D	24
	RH4*107*DA	A-12	A-30	OSE-12-Z	OSE-21-Z	SER-D	SERI-F	27
	RH4*131*DA	A-15	A-35	OSE-12-Z	OSE-30-Z	SER-D	SERI-F	36
	RH4*167*DA	A-20	A-40	OSE-21-Z	OSE-30-Z	SERI-F	SERI-G	36

### R407A/ R448A/ R449A†

6 FPI	RH6*033*DA	E-2-1/2	E-6	SBFDE-C-Z	ODE-7-Z	SER-B	SER-C	9
	RH6*044*DA	E-4	E-8	EBSDE-7-Z	ODE-12-Z	SER-C	SER-C	9
	RH6*053*DA	E-5	E-12	EBSDE-7-Z	ODE-12-Z	SER-C	SER-C	12
	RH6*066*DA	C-6	C-15	EBSDE-10-Z	ODE-12-Z	SER-C	SER-D	18
	RH6*089*DA	C-8	C-17	ODE-12-Z	ODE-17-Z	SER-D	SER-D	18
	RH6*109*DA	C-12	C-25	ODE-17-Z	ODE-28-Z	SER-D	SER-D	24
	RH6*134*DA	A-15	A-30	ODE-17-Z	ODE-28-Z	SER-D	SERI-F	27
4 FPI	RH4*035*DA	E-3	E-6	SBFDE-C-Z	ODE-7-Z	SER-C	SER-C	9
	RH4*044*DA	E-4	E-8	SBFDE-C-Z	ODE-7-Z	SER-C	SER-C	12
	RH4*071*DA	C-6	C-15	ODE-12-Z	ODE-12-z	SER-C	SER-D	18
	RH4*087*DA	C-8	C-17	ODE-12-Z	ODE-17-Z	SER-D	SER-D	24
	RH4*107*DA	A-12	A-20	ODE-17-Z	ODE-28-Z	SER-D	SER-D	27
	RH4*131*DA	A-15	A-30	ODE-17-Z	ODE-28-Z	SER-D	SERI-F	36
	RH4*167*DA	A-17	A-35	ODE-28-Z	ODE-40-Z	SERI-F	SERI-G	36

Note: The distributor lines are 1/4" tube & 31" long.

\* Each asterisk represents a variable character based on defrost and voltage ordered. See page 4 for nomenclature.

<sup>^</sup> TXV selections for Hot Gas Defrost Models are based on -20°F suction temp., 8°F to 12°F evaporator TD. Contact factory for operating conditions outside of this range. Do not use pressure limiting TXVs when the condensing unit includes a CPR valve.

† SBFDE, ODE, and EBSDE expansion valves are compatible with R407A, R448A and R449A/B. For other valves, follow manufacturers selection guidelines.

Base models (no factory-mounted components) include nozzles sized for 100°F liquid shipped loose.

# HEAVY DUTY UNIT COOLER

## Specifications - Air Defrost Models

Models	Fan Dia. (Inches)	Motor Data			Refrigerant Connections		No. of Hanger Slot Locations	Figure	Unit Dimensions (Inches)			Est. Unit Wt. (Lbs.)
		Motor Qty.	HP	RPM	Liquid Line <sup>^</sup>	Suction Line			L	W	H	
<b>6 FPI</b>												
RH6A031*DA	30	1	3/4	850	1/2	1-1/8	4	1	59-7/8	27-3/8	49-1/4	293
RH6A043*DA	30	1	3/4	850	1/2	1-3/8	4	1	59-7/8	27-3/8	49-1/4	293
RH6A052*DA	30	1	3/4	850	5/8	1-5/8	4	1	59-7/8	27-3/8	49-1/4	293
RH6A063*DA	30	2	3/4	850	5/8	1-5/8	6	2	99-7/8	27-3/8	49-1/4	489
RH6A087*DA	30	2	3/4	850	7/8	2-1/8	6	2	99-7/8	27-3/8	49-1/4	489
RH6A105*DA	30	2	3/4	850	7/8	2-1/8	6	2	99-7/8	27-3/8	49-1/4	489
RH6A132*DA	30	3	3/4	850	7/8	2-1/8	8	3	139-7/8	27-3/8	49-1/4	652
RH6A156*DA	30	3	3/4	850	1-1/8	2-1/8	8	3	139-7/8	27-3/8	49-1/4	652
RH6A175*DA	30	4	3/4	850	1-1/8	2-1/8	10	4	179-7/8	27-3/8	49-1/4	837
RH6A209*DA	30	4	3/4	850	1-1/8	2-1/8	10	4	179-7/8	27-3/8	49-1/4	837

\* Each asterisk represents a variable character based on voltage ordered. See page 4 for nomenclature.

<sup>^</sup> For units with mounted TXV components. See Nozzle/TXV table for distributor connection size when TXV is field installed.

1. For dimensional distance between hanger slots, consult model's corresponding dimension drawing. Hanger slots are 1/2" deep x 1" wide.

2. Drain is 1-1/4" NPT for all models.

<sup>+</sup> If the model has a numerical value in the AWEF table below, the following statement applies: "The refrigeration system is designed and certified for use in walk-in cooler applications less than 3,000 sq. ft."

Shipping Information - All Models				
No. of Fans	Shipping Dimensions (Inches)			Est. Ship Wt. (Lbs.)
	L	W	H	
1	69	42	66	470
2	109	42	66	730
3	146	42	66	1,000
4	189	42	66	1,130

Department of Energy Annual Walk-In Energy Factor (AWEF) Ratings		
Base Model Number	FPI	AWEF
<b>Cooler Models<sup>+</sup> - Air Defrost</b>		
R*6A031*DA	6	9.0
R*6A043*DA	6	9.0
R*6A052*DA	6	9.0
R*6A063*DA	6	9.0
R*6A087*DA	6	9.0
R*6A105*DA	6	9.0
R*6A132*DA	6	9.0
R*6A156*DA	6	9.0
R*6A175*DA	6	9.0
R*6A209*DA	6	9.0

### TYPICAL APPLICATIONS:



Medium to Large Warehouses



Cold Storage Warehouses



Walk-in Coolers and Freezers

# HEAVY DUTY UNIT COOLER

## Specifications - Electric and Hot Gas Defrost Models

Model Number RH*E/H/ G/ K/ L	Fan Dia. (Inches)	Motor Data			Refrigerant Connections			No. of Hanger Slot Locations	Figure	Unit Dimensions (Inches)			Est. Unit Wt. (Lbs.)
		Motor Qty.	HP	RPM	Liquid Line <sup>^</sup>	Suction Line	3-Pipe Hot Gas Line			L	W	H	

### 6 FPI

RH6*033*DA	30	1	3/4	850	1/2	2-1/8	1-1/8	4	1	59-7/8	27-3/8	49-1/4	293
RH6*044*DA	30	1	3/4	850	5/8	2-1/8	1-1/8	4	1	59-7/8	27-3/8	49-1/4	293
RH6*053*DA	30	1	3/4	850	5/8	2-1/8	1-1/8	4	1	59-7/8	27-3/8	49-1/4	293
RH6*066*DA	30	2	3/4	850	5/8	2-1/8	1-1/8	6	2	99-7/8	27-3/8	49-1/4	489
RH6*089*DA	30	2	3/4	850	7/8	3-1/8	1-1/8	6	2	99-7/8	27-3/8	49-1/4	489
RH6*109*DA	30	2	3/4	850	7/8	3-1/8	1-1/8	6	2	99-7/8	27-3/8	49-1/4	489
RH6*134*DA	30	3	3/4	850	1-1/8	3-1/8	1-3/8	8	3	139-7/8	27-3/8	49-1/4	652
RH6*163*DA	30	3	3/4	850	1-1/8	3-1/8	1-3/8	8	3	139-7/8	27-3/8	49-1/4	652
RH6*199*DA	30	4	3/4	850	1-1/8	3-1/8	1-3/8	10	4	179-7/8	27-3/8	49-1/4	837

### 4 FPI

RH4*035*DA	30	1	3/4	850	1/2	2-1/8	1-1/8	4	1	59-7/8	27-3/8	49-1/4	293
RH4*044*DA	30	1	3/4	850	5/8	2-1/8	1-1/8	4	1	59-7/8	27-3/8	49-1/4	293
RH4*071*DA	30	2	3/4	850	5/8	2-1/8	1-1/8	6	2	99-7/8	27-3/8	49-1/4	489
RH4*087*DA	30	2	3/4	850	7/8	3-1/8	1-1/8	6	2	99-7/8	27-3/8	49-1/4	489
RH4*107*DA	30	3	3/4	850	7/8	3-1/8	1-3/8	8	3	139-7/8	27-3/8	49-1/4	652
RH4*131*DA	30	3	3/4	850	1-1/8	3-1/8	1-3/8	8	3	139-7/8	27-3/8	49-1/4	652
RH4*167*DA	30	4	3/4	850	1-1/8	3-1/8	1-3/8	10	4	179-7/8	27-3/8	49-1/4	837

### Department of Energy Annual Walk-In Energy Factor (AWEF) Ratings

Base Model Number	FPI	AWEF
-------------------	-----	------

#### Cooler Models<sup>+-</sup> - Electric and Hot Gas Defrost

R*6*033*DA	6	9.0
R*6*044*DA	6	9.0
R*6*053*DA	6	9.0
R*6*066*DA	6	9.0
R*6*089*DA	6	9.0
R*6*109*DA	6	9.0
R*6*134*DA	6	9.0
R*6*163*DA	6	9.0
R*6*199*DA	6	9.0

### Department of Energy Annual Walk-In Energy Factor (AWEF) Ratings

Base Model Number	FPI	AWEF
-------------------	-----	------

#### Freezer Models<sup>++</sup> - Electric and Hot Gas Defrost

R*6*033*DA	6	4.15
R*6*044*DA	6	4.15
R*6*053*DA	6	4.15
R*6*066*DA	6	4.15
R*6*089*DA	6	4.15
R*6*109*DA	6	4.15
R*6*134*DA	6	4.15
R*6*163*DA	6	4.15
R*6*199*DA	6	4.15
R*4*035*DA	4	4.15
R*4*044*DA	4	4.15
R*4*071*DA	4	4.15
R*4*087*DA	4	4.15
R*4*107*DA	4	4.15
R*4*131*DA	4	4.15
R*4*167*DA	4	4.15

\* Each asterisk represents a variable character based on style, defrost and voltage ordered. See page 4 for nomenclature.

<sup>^</sup> For units with mounted TXV components. See Nozzle/TXV table for distributor connection size when TXV is field installed.

1. For dimensional distance between hanger slots, consult model's corresponding dimension drawing. Hanger slots are 1/2" deep x 1" wide.

2. Drain is 1-1/4" NPT for all models.

3. For shipping dimensions and weights, see Shipping Information table on page 13.

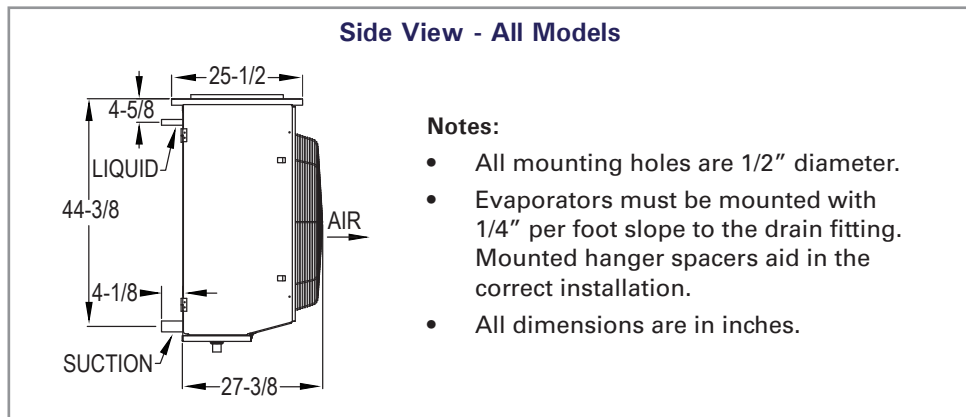
+ If the model has a numerical value in the table above, the following statement applies: "The refrigeration system is designed and certified for use in walk-in cooler applications less than 3,000 sq. ft."

++ If the model has a numerical value in the table above, the following statement applies: "The refrigeration system is designed and certified for use in walk-in freezer applications less than 3,000 sq. ft."

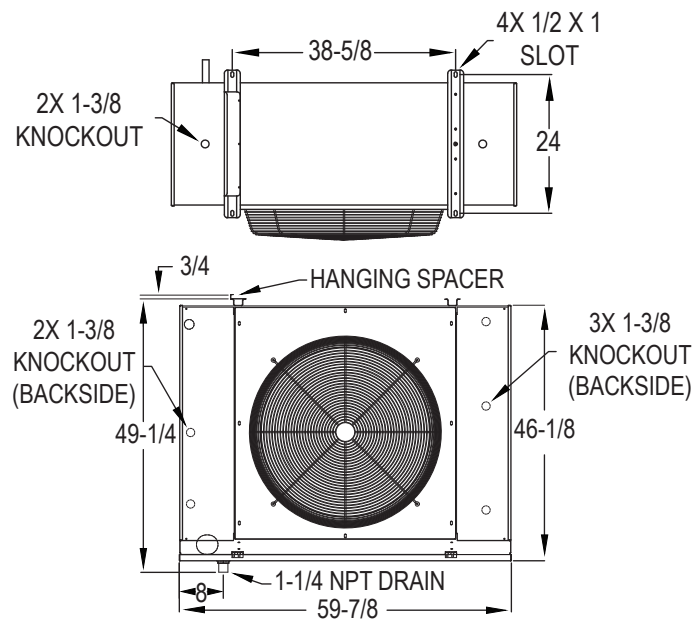


# HEAVY DUTY UNIT COOLER

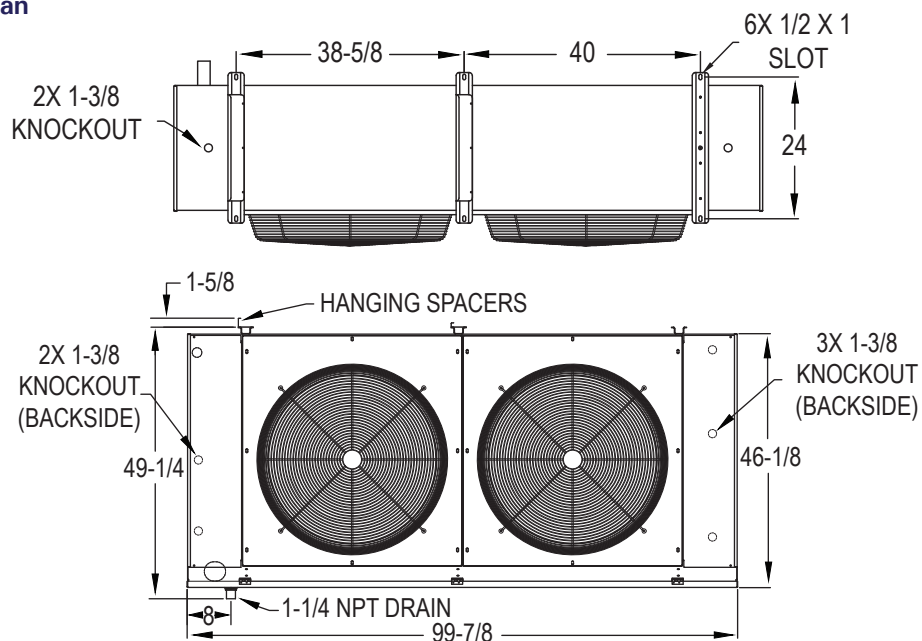
## Physical Dimensions



**Figure 1 - Single Fan**

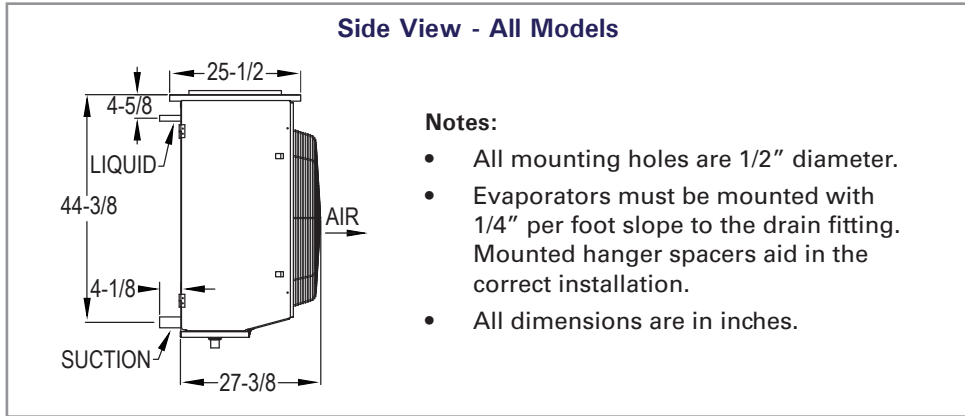


**Figure 2 - Two Fan**

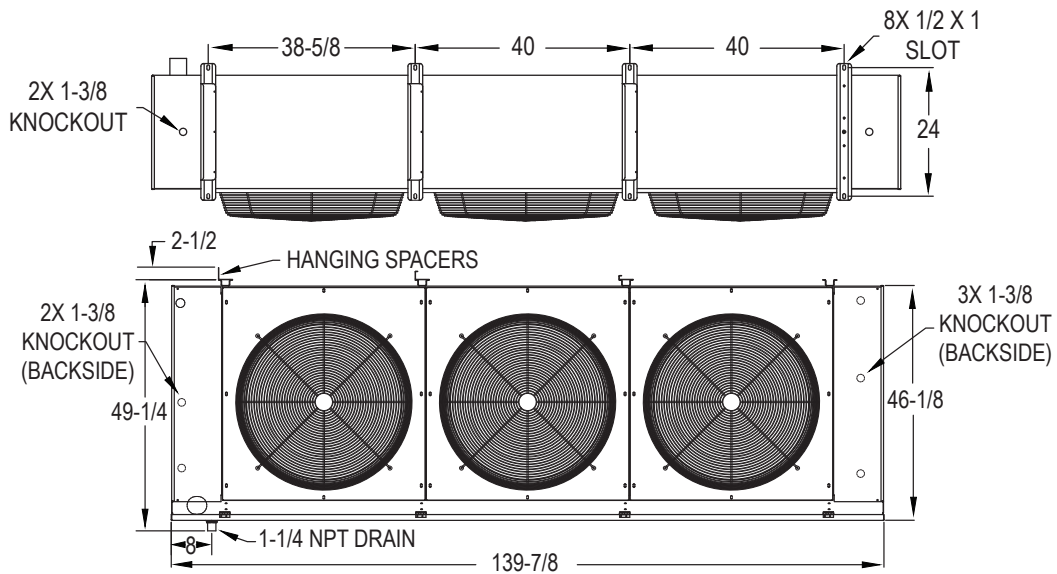


# HEAVY DUTY UNIT COOLER

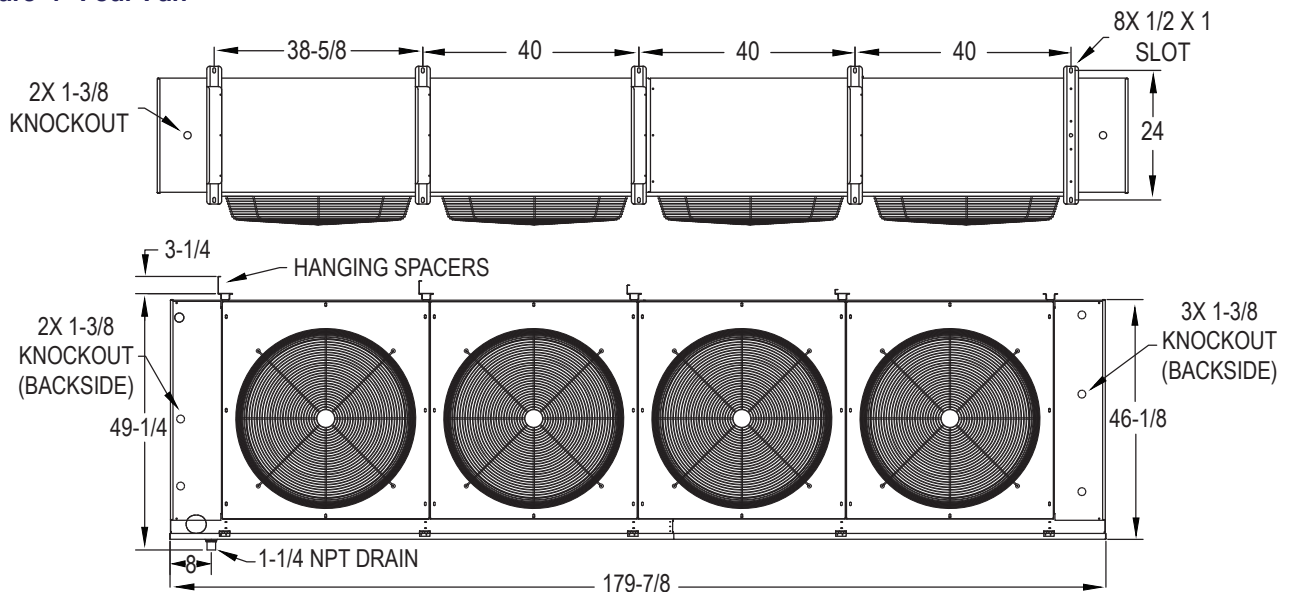
## Physical Dimensions



**Figure 3 - Three Fan**



**Figure 4- Four Fan**



*Due to continuing product development, specifications are subject to change without notice.*